

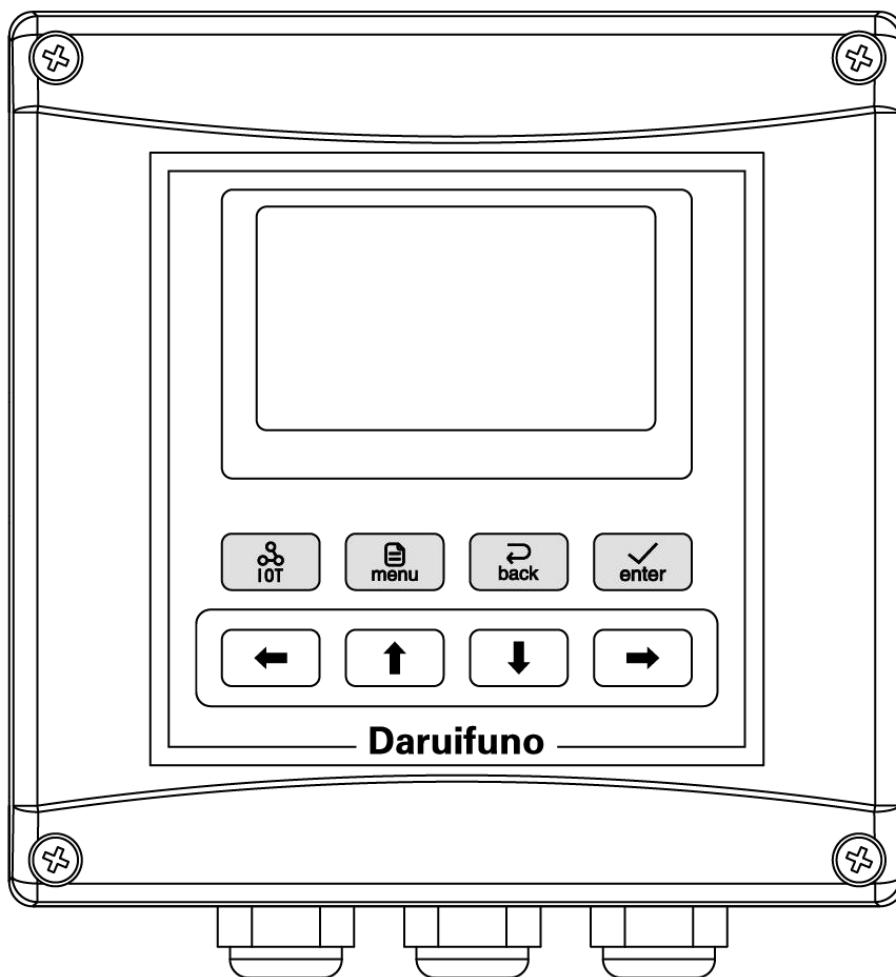

# COD Controller

## User Manual





## Important Safety Information

Please read and observe the following:

Please read this entire manual before unpacking, installation and operation, with particular attention to all danger warnings and precautions. Failure to do so may result in damage to the instrument or personal injury to the operator due to misuse. Do not install or use the instrument by any means other than those specified in this manual.

- After opening the analyzer case, the user may touch the instrument supply voltage. Please make sure to disconnect the power, before you open the analyzer cases. Analyzer housing assembly only low voltage, the operation is safe.
- The analyzer must be installed in accordance with relevant local codes and the professional and technical personnel, to comply with the analyzer's technical specifications and input ratings. If you are not sure which of the main power lines is the zero line, use a double-blade switch to disconnect the analyzer.
- As soon as a problem occurs with the analyzer, disconnect the analyzer from power to prevent any unintentional operation that could result in damage to the instrument. For example, it may be in an unsafe state when the following situations occur:
  - ( 1 ) The analyzer appears visibly damaged;
  - ( 2 ) Analyzer fails to operate properly or provide the intended measurements;
  - ( 3 ) Analyzer has been stored for a long period of time at temperatures over 70°C environment.
- Wiring or repair should be done by professionals, and only the power-off analyzer should be operated.

## Power Wiring Note

1. Please install voltage stabilization and surge protection equipment that meets the instrument parameters at the power supply terminal to ensure that the power supply provided by the instrument is stable and reliable and meets the standards, otherwise the instrument will be irreversibly damaged due to poor power supply.
2. Damage caused by incorrect power supply is not covered by our quality guarantee.
3. Detailed parameters see the technical parameters.

## Useful signs

In addition to installation and operation information, the manual also includes warning signs related to user safety, caution signs related to possible instrument failure, and note signs related to important and useful operating instructions.

**Warning:**

The warning sign is shown above, which warns the user might get hurt

**Caution:**

The caution sign is shown above, it reminds the user that the instrument may malfunction or be damaged



The note sign is shown on the left, warns the user of important information about operation.

## **Guarantee**

Our company warrants the instrument for one year (12 months) from the date of delivery. Consumables and consumable parts in the equipment are not covered by the warranty. The terms of this warranty shall not apply if damage to the instrument occurs beyond the warranty period, or in the opinion of the company, the breakage or destruction of the instrument is due to improper use, lack of maintenance, improper installation, improper modification, abnormal environmental conditions, etc. The company's obligation under this warranty is limited to providing replacement or repair of this product, as the case may be. The product must be thoroughly cleaned to remove any contaminated chemicals before it is accepted for replacement or repair. Our obligations shall not exceed the price of the product itself. In no event shall the company be liable for damage caused by incidental or consequential damages, whether to persons or objects. The company shall not be liable for any other loss, damage or expense of any kind, including economic loss resulting from the installation, use or improper use of the product.

- For details, please refer to the product's quality promise with the product, and keep this manual and the quality promise properly.

# Table of Contents

## Part 1 Introduction

<b>Chapter 1</b>	<b>Overview</b>	
	1.1 Technical parameters .....	1

## Part 2 Installation

<b>Chapter 2</b>	<b>Unpacking.....</b>	<b>2</b>
<b>Chapter 3</b>	<b>Mechanical Installation</b>	
	3.1 Installation location .....	2
	3.2 Instrument size .....	3
	3.3 Panel installation .....	3
	3.4 Wall mounting .....	4
	3.5 Pipe installation .....	5
<b>Chapter 4</b>	<b>Electrical Installation</b>	
	4.1 Power connection .....	6
	4.2 Wiring terminals definition. ....	7

## Part 3 Operation

<b>Chapter 5</b>	<b>User Interface</b>	
	5.1 Button .....	8
	5.2 Display .....	9
<b>Chapter 6</b>	<b>System Default Settings .....</b>	<b>11</b>
<b>Chapter 7</b>	<b>Menu Description</b>	
	7.1 Electrode settings. ....	12
	7.2 Alarm settings. ....	12
	7.2.1 Control functions .....	12
	7.2.2 Cleaning output .....	12
	7.2.3 Cleaning state .....	13
	7.2.4 Ambient temperature alarm. ....	13

7.3 Current settings . . . . .	13
7.3.1 Output type . . . . .	13
7.3.2 Channel selection . . . . .	13
7.3.3 Upper limit value. . . . .	13
7.3.4 Lower limit value . . . . .	13
7.4 Communication settings. . . . .	14
7.4.1 Slave address . . . . .	14
7.4.2 Baud rate . . . . .	14
7.4.3 Check bit . . . . .	14
7.4.4 Stop bit . . . . .	14
7.5 System settings . . . . .	14
7.5.1 System language . . . . .	14
7.5.2 Time setting. . . . .	14
7.5.3 Display rate . . . . .	14
7.5.4 Backlight selection. . . . .	14
7.5.5 Contrast setting . . . . .	14
7.5.6 Version information. . . . .	14
7.5.7 Password setting . . . . .	14
7.6 History record. . . . .	14
7.6.1 Memory information . . . . .	14
7.6.2 Recording interval . . . . .	14
7.6.3 Data query . . . . .	15
7.7 Test maintenance . . . . .	15
7.7.1 Current calibration . . . . .	15
7.7.2 Relay testing . . . . .	15
7.7.3 Current testing . . . . .	15
7.7.4 Measurement method . . . . .	15
7.7.5 Ambient temperature . . . . .	15
7.7.6 Meter reset . . . . .	15
7.8 Setting list . . . . .	15

## Appendix

A Modbus register information . . . . .	16
Menu structure diagram . . . . .	18

## Part 1 Introduction

### Chapter 1

#### Overview

This product is a digital analytical instrument. According to the measurement object, it is connected to a digital electrode to measure various material parameters. The meter supports two current outputs, one digital communication output and two control relays with configurable functions.

#### 1.1 Technical parameters

Relay Control: Channel Quantity: 2

Control Type: high or low alarm/cleaning control/Ambient temperature alarm

Contact Type: SPST

Contact Capacity: 3A 250VAC

Current Output: Channel Quantity: 2

Output Type: active 4~20mA or 0~20mA

Maximum Load: 1000  $\Omega$

Communication Interface: RS485 MODBUS-RTU

Memory Backup: All user settings are kept in EEPROM indefinitely

Historical Data: 14000 storage points, record interval can be set

Operating Environment: 0~+60°C, RH 0~95%, no condensation

Storage Environment: -20~+70°C, RH 0~95%, no condensation

Power Requirement: 100~240VAC or 18~36VDC, 24W MAX

Installation Method: Panel mounting, wall mounting, pipe installing

Instrument Size: 144\*144\*120 (unit: mm)

Protection Grade: IP66

Instrument Weight: about 800g

## Part 2 Installation

### Chapter 2

#### Unpacking

After unpacking, it is recommended that the shipped cardboard boxes and packing materials be saved for instrument storage or reshipment. Inspect equipment and packing materials for signs of damage during shipment. If there are signs of damage, immediately notify the person delivering the shipment.

### Chapter 3

#### Mechanical Installation

#### 3.1 Installation location

The installation location of the meter is:

Unaffected by weather (rain, snow, ice, dust, etc.)

- Clean, dry and with little or no vibration
- Keep away from corrosive liquids
- Within ambient temperature limits (32~140°F or 0~60°C)

#### Caution:

Analyzer directly exposed to the sun, its operating temperature may exceed its specified limit temperature, and will reduce the visibility of the display.



**Note:** Please read this operation manual thoroughly before installation to avoid damage to the instrument due to wrong wiring.

- Please choose a well-ventilated location to install the instrument to avoid direct sunlight.
- The electrode signal transmission must use specific cables or cables provided by our company, and cannot be replaced by random wires.
- When using AC220V power supply, avoid using three-phase power supply to avoid power spike interference (if power spike interference occurs, the power supply of the controller can be separated from the power supply of the control device, so that the controller uses a separate power supply, or the coil ends of all electromagnetic switches and power control devices are connected to spike absorbers to eliminate spikes, such as dosing machines, mixers, etc.).
- It is generally recommended that the controller be accessible to the electrode during installation.
- Avoid corrosive liquids, or need to protect and isolate the environment.



### 3.2 Instrument size

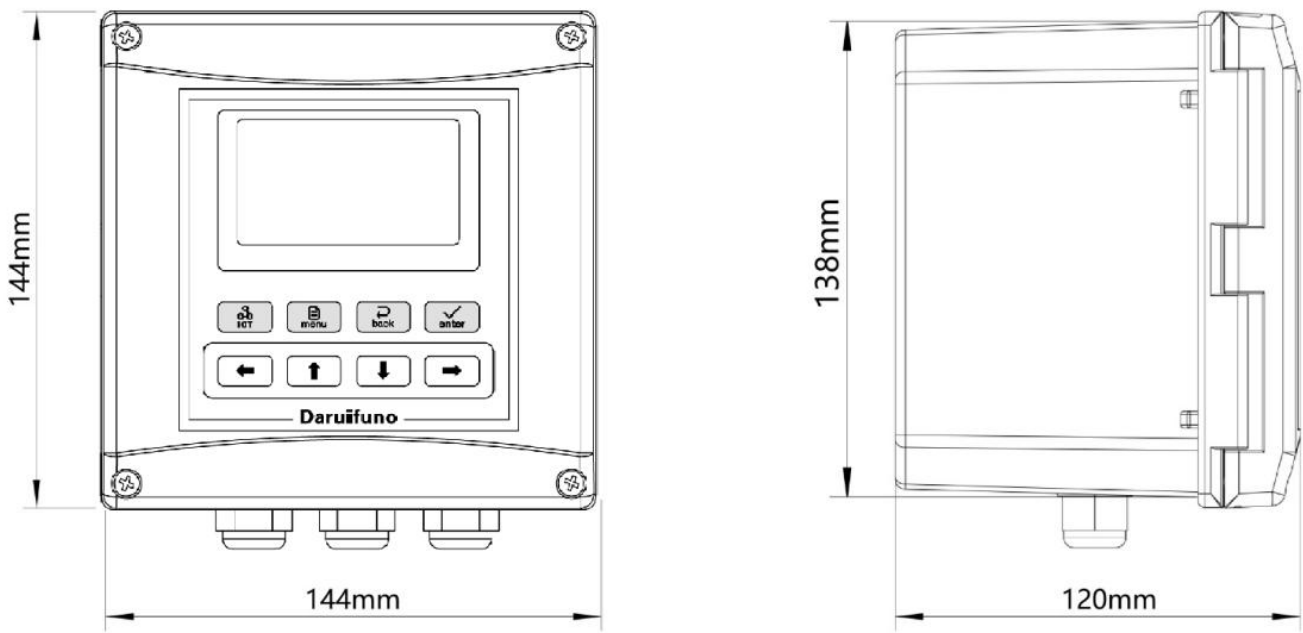

Figure 3-1 Instrument size

### 3.3 Panel installation

When the instrument is installed in a panel cabinet, use two fixing brackets to fix the instrument. The installation diagram is as follows:

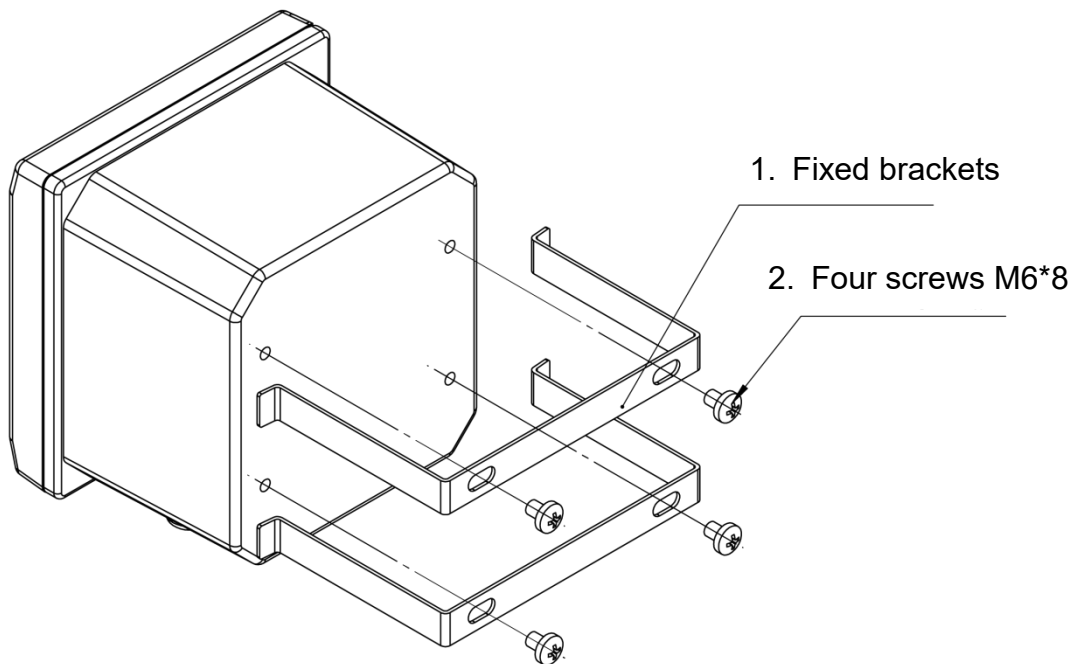

Figure 3-2 Panel mounting

3.4 Wall mounting

Connect the gray back panel to the instrument, and then install it on the box or the side wall of the wall. The installation dimensions and schematic diagram are as follows:

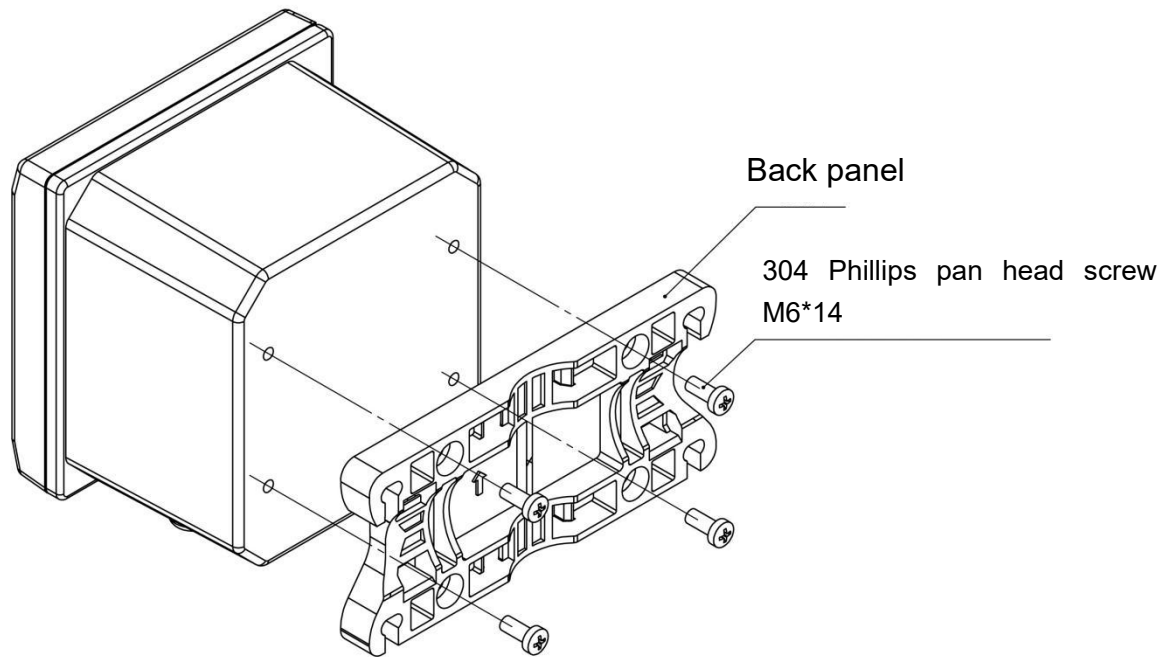

Figure 3-3 Wall mounting

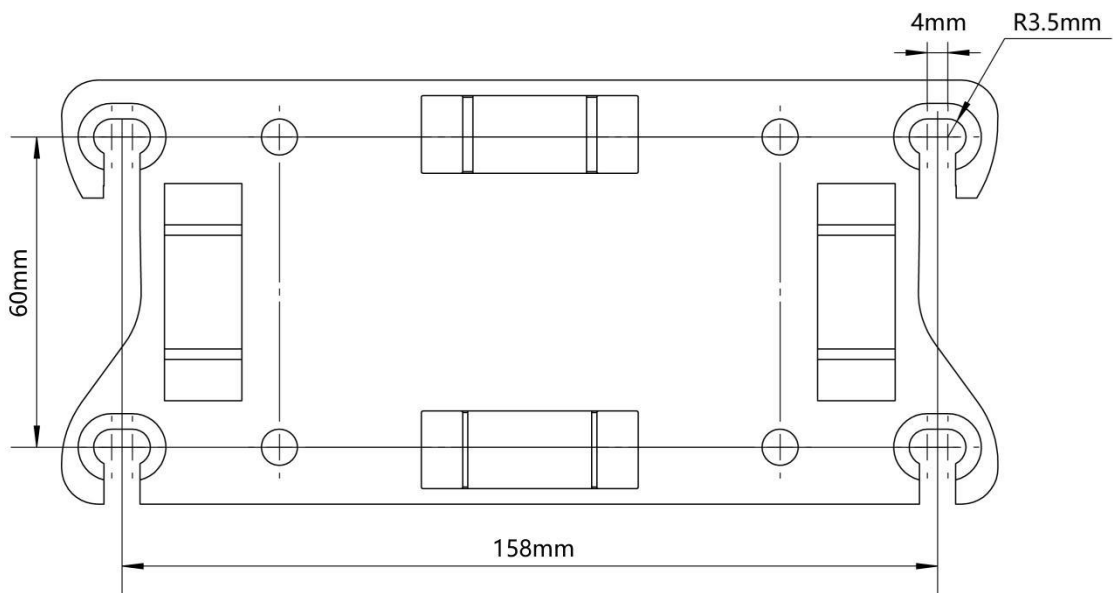

Figure 3-4 Wall mounting hole size dimensional drawing

### 3.5 Pipe installation

Connect the gray back panel to the instrument, and then fix the back panel to the horizontal pipe or vertical pipe with a clamp. The installation diagram is shown below

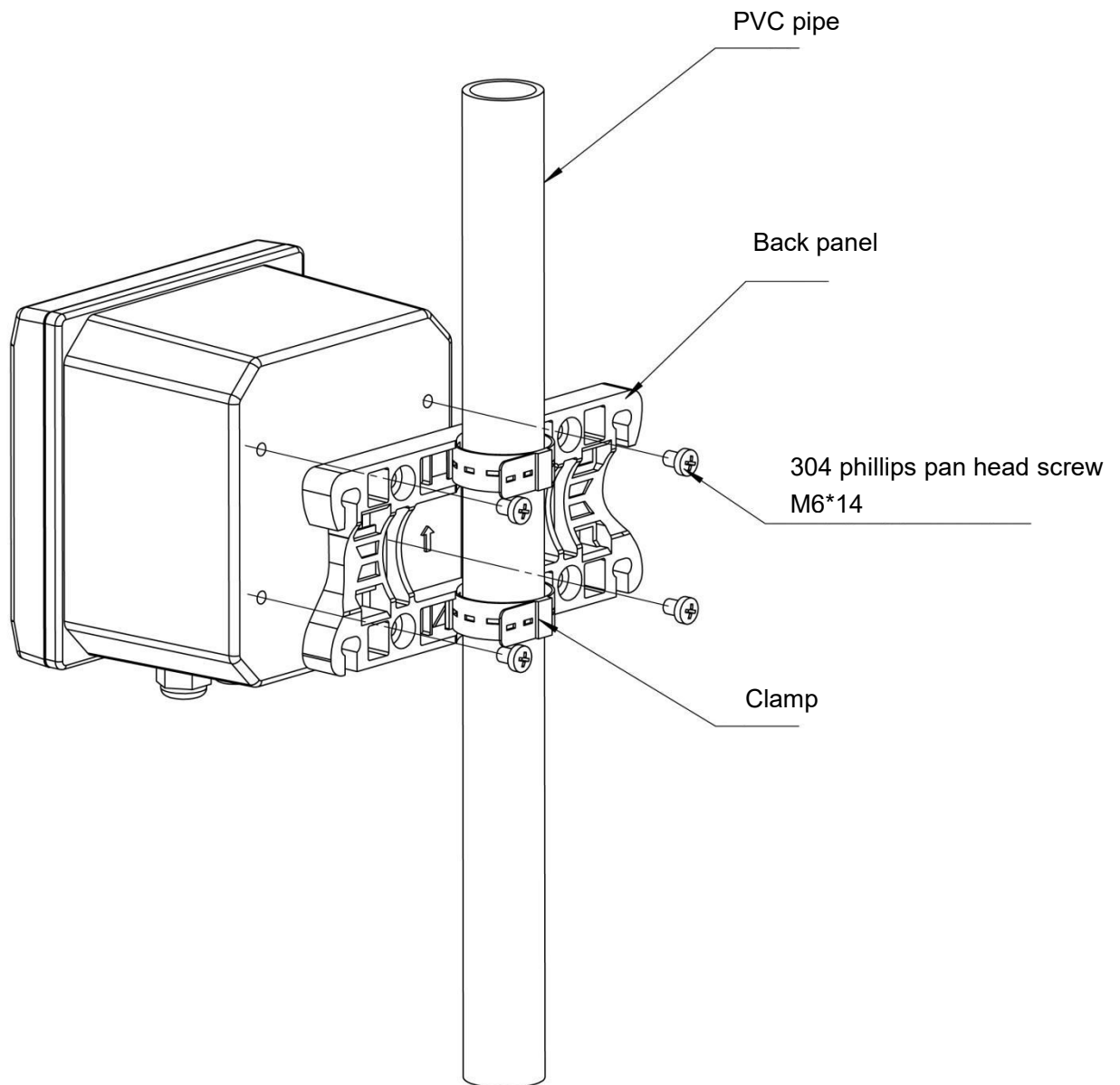

Figure 3-5 Pipe installation

— — — Chapter 4 — — —

**Electrical Installation**

4.1 Power connection

Two types of power supply: AC power supply 100~240VAC and DC power supply 18~36VDC.  
After unscrewing the screws at the back of the meter and taking off the cover, you can see two rows of terminals.  
Figure 4-1 indicates the location and name of the access terminals for both power supplies.



**Note: Before connecting AC power, be sure to cut off the power supply and operate only in the power-off state!**

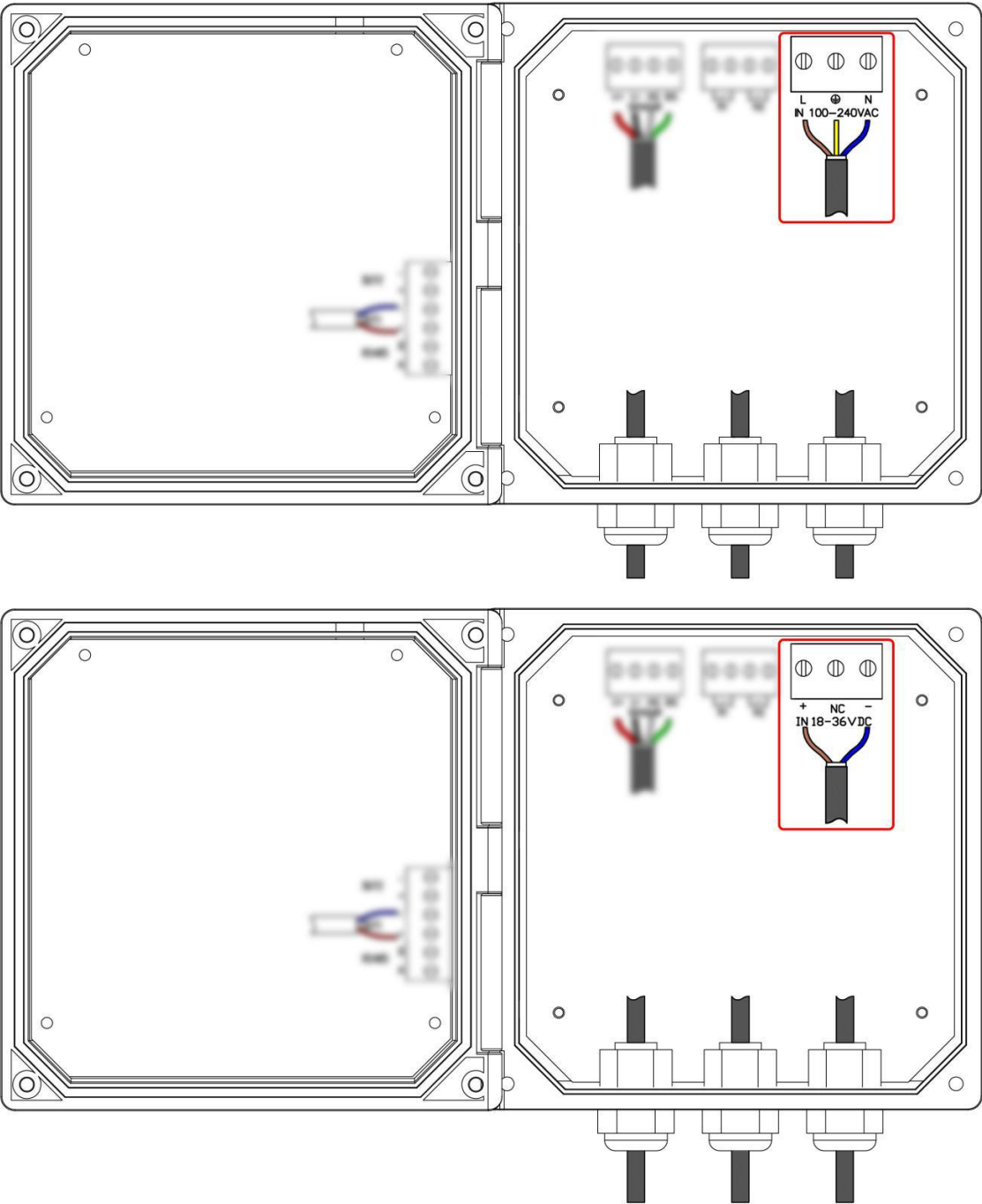

Figure 4-1 Two types of power terminals

The following table shows the definition of two power supply terminals:

POWER AC IN 100-240V	L	AC power fire wire input	POWER DC IN 18-36V	+	DC power positive
		AC power ground wire		NC	Floating terminal
	N	AC power zero line input		-	DC power negative

Table 4-1 Two types of power terminals definition

4.2 Wiring terminals definition

The terminal positions and names of each series of models are shown in the figure below:

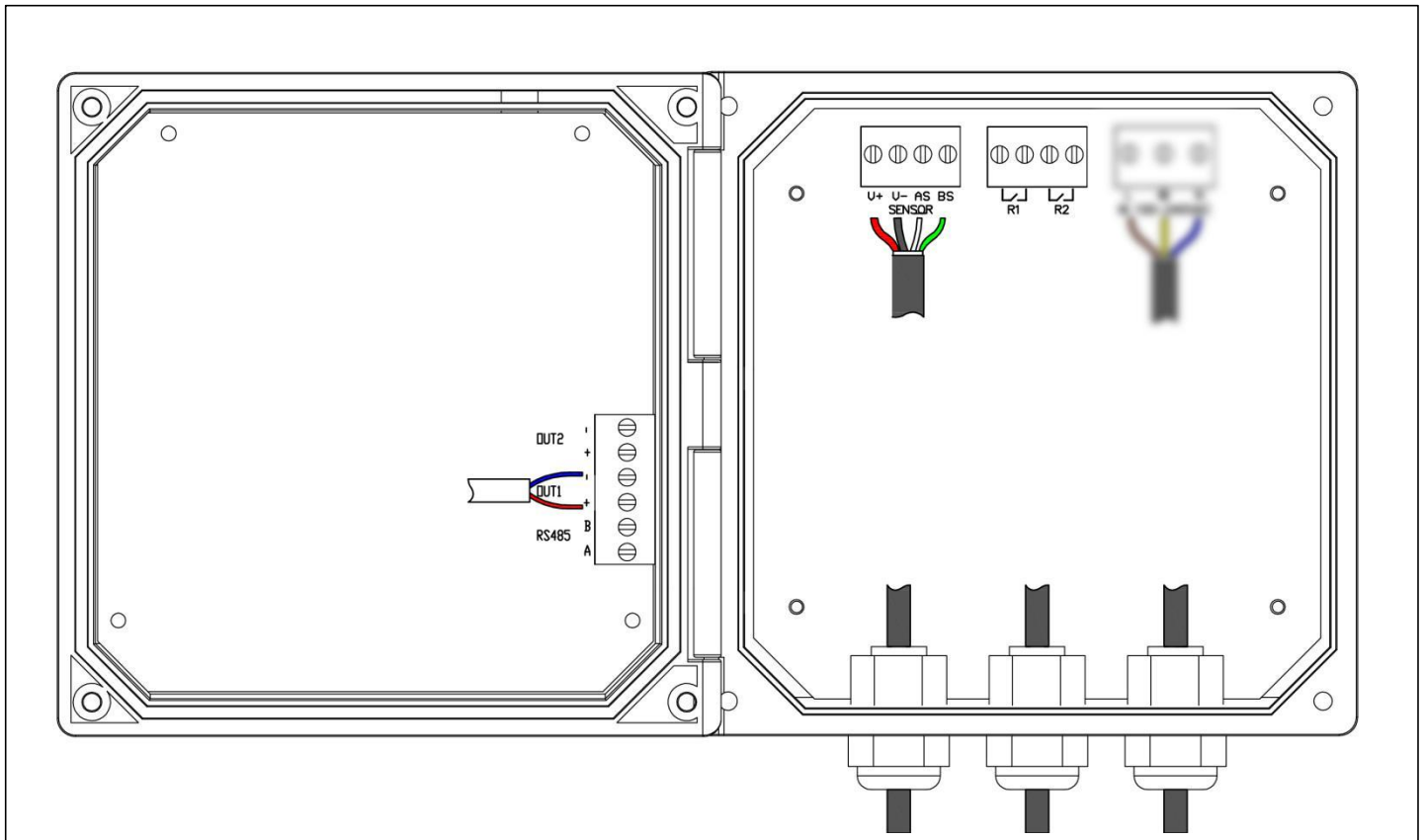

The following table is the terminal definition:

OUT2	+	Current 2 Output positive	V-	Electrode power-terminal
	-	Current 2 Output negative	V+	Electrode power+terminall
OUT1	+	Current 1 Output positive	BS	Electrode communication terminal B
	-	Current 1 Output negative	RELAY1	Relay 1 contact
RS485	A	RS485 signal D+(A) terminal		RELAY2
	B	RS485 signal D-(B) terminal		Relay 2 contact
AS		Electrode communication terminal A		Relay 2 contact

## Part 3 Operation

### Chapter 5

#### User Interface

The instrument panel consists of a display screen and eight buttons, namely IOT (Internet of Things) button, menu button, back button, enter button, and up, down, left and right arrow keys. As shown below:

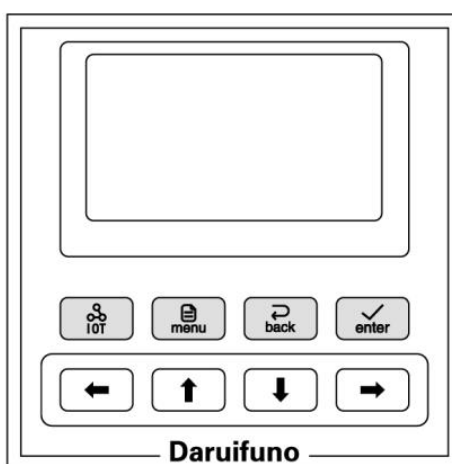

#### 5.1 Button

**Up key:** Press this key in the menu option interface to move the cursor up; press this key in the parameter setting interface to increase the data by 1 (change in the order of 0, 1, 2.... 9, 0); in the measurement interface.

**Down key:** Press this key in the menu option interface to move the cursor down; press this key in the parameter setting interface to reduce the data by 1 (change in the order of 9, 8, 7... 0, 9); in the measurement interface, Press this key can switch three kinds of secondary displays: "temperature & electrode connection status" → "relay status" → "two currents".

**Left key:** In the parameter setting interface, press this key to move the cursor left; in the menu interface, press this key to return to the previous menu;

**Right key:** In the parameter setting interface, press this key to move the cursor right

**Internet of Things key:** Short press this key in the measurement interface to turn on or off the Internet of Things function, and long press to enter the Internet of Things setting menu.



**Note:** The IoT key function is only supported by instruments with hardware version CO and above.

**Menu button:** Press this key in the measurement interface to enter the menu interface, press this key in the menu option interface to directly return to the measurement state, press this key in the parameter setting interface to return to the previous menu.

**Enter button:** In the menu option interface, press this key to select the option; in the parameter setting interface, press this key to confirm and return to the previous menu.

**Return button:** press this key to return to the previous menu, such as in the parameter setting interface, press this key to abandon the modification and return to the previous menu single.

5.2 Display

The meter normally displays the measurement interface after power-on. The specific information is as follows:

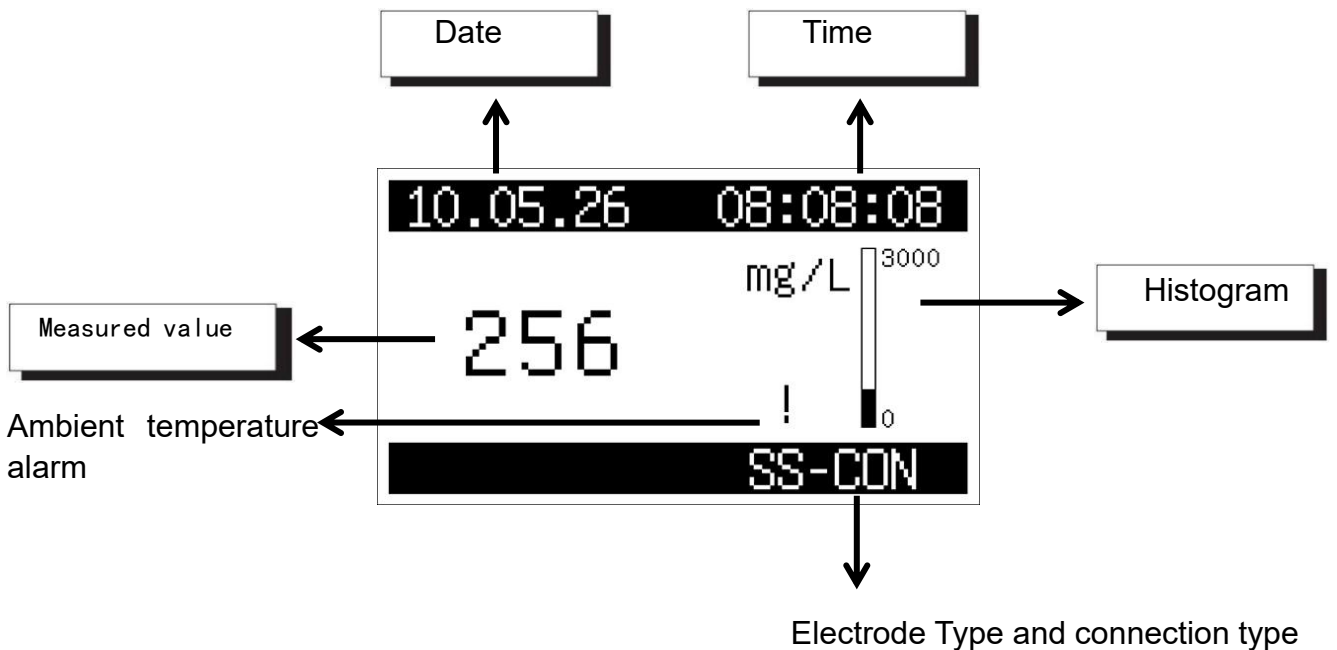

**Date and time:** Display current date and time information.

**Measured value:** Shows the current measurement value, the unit changes according to the measurement object.

When "<" appears in front of the measured value, it means that the current measured value is lower than the zero point, and zero point calibration is required.

When ">" appears in front of the measured value, it means that the current measured value exceeds the display range of the meter.

**Histogram:** Indicates the ratio of the current measured value to the range.

**Ambient temperature alarm:** When the operating environment temperature exceeds 50°C, a "!" will appear on the screen, indicating that the working environment temperature of the instrument is too high, and heat dissipation measures are needed.

**Electrode Type:** Displays the currently selected electrode type.

No electrode connection: XX-NC

Electrode connection: XX-CON

Analog measurement: XX EMLUATOR (flashing)



## Chapter 6

## system Default Settings

Setting type		Setting option	Factory settings
Alarm setting	Relay 1	Function set	Main measurement
	Relay 2	Function set	Main measurement
Current setting	Current 1	Output type	4-20mA
	Current 2	Output type	4-20mA
Communication setting	Slave address		001
	Baud rate		9600bps
	Check bit		No parity
	Stop bit		1bit
System setting	System language		Chinese
	Display rate		Buffer level 8
	Backlight selection		Energy saving 01min
	Contrast setting		25
	Password setting		000000
Historical recording	Recording interval		5min
Test maintenance	Measuring method		Sensor measuring
	Ambient temperature calibration		25°C
Buzzer alarm	Close, open		Close

## Chapter 7

### Menu Description

In the measurement interface, long press the MENU button to enter the menu. The following is a detailed introduction to the menu content.

#### 7.1 Electrode settings

According to the measurement object, the meter is connected to different electrodes, and the menu items are set according to the electrode type. For details, please refer to the "Digital Universal Controller Electrode Setting Instructions".

#### 7.2 Alarm settings

The meter provides two completely independent relay output contacts, corresponding to the "Relay 1" and "Relay 2" menus, which allow the user to set the functions and parameters of the two relays separately.

##### 7.2.1 Control function

When selecting "Main measurement control" or "Temperature control" in the "Main menu" -> "Alarm set" -> "Relay X" -> "Function set" menu, this relay is the control output relay. When "Main Measurement Control" is selected, the relay status is controlled by the main measurement; when "Temperature Control" is selected, the relay is controlled by the temperature measurement.

When "on value" > "off value" is set in the menu, the relay is high alarm control  
When "on value" < "off value" is set in the menu, the relay is low alarm control

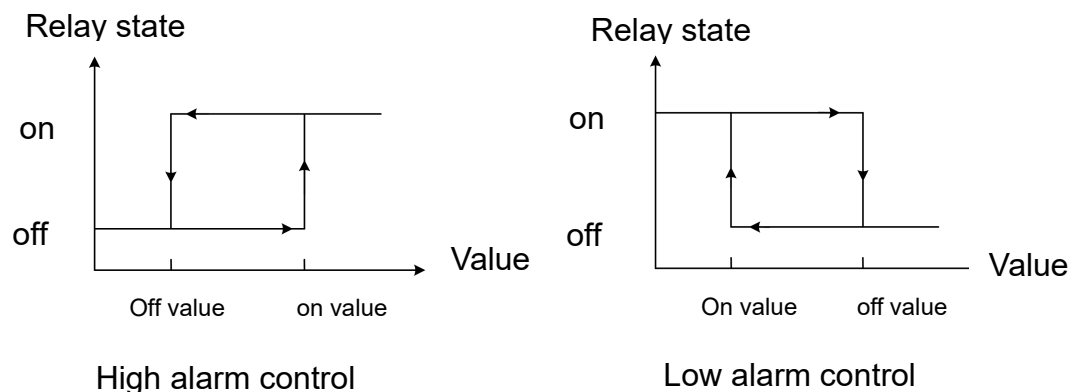

##### 7.2.2 Cleaning output

When selecting "Cleaning Output" in "Main Menu" -> "Alarm Set" -> "Relay X" -> "Function Set" menu, the relay is in the cleaning output state, the relay can be closed periodically to do cleaning control.

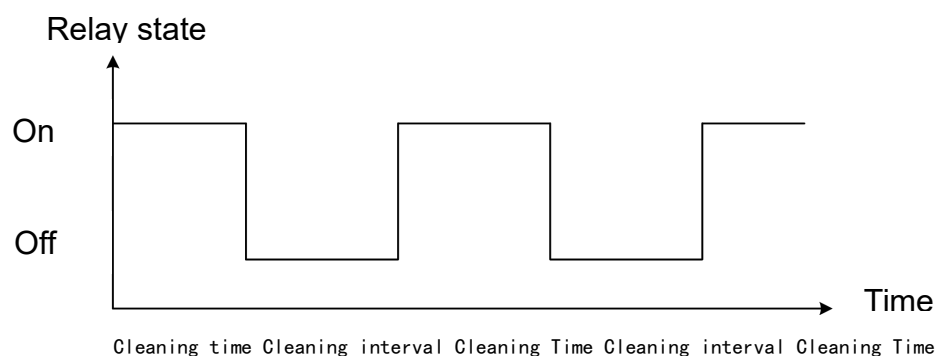

7.2.3 Cleaning state

Select the status of the measured value during cleaning.  
 After selecting “Keep”, when cleaning, the measured value displayed maintains the value before the relay action.  
 After selecting “Continuous”, the measured value is the real-time value of continuous measurement.

7.2.4 Ambient temperature alarm

When “Ambient Temperature Alarm” is selected in the “Main Menu” -> “Alarm Setting” -> “Relay X” -> “Function Setting” menu, the relay is in the alarm control output state. The relay status is controlled by the meter's operating ambient temperature. When the ambient temperature exceeds 50°C, the relay closes.

7.3 Current settings

The instrument provides two independently configurable current signals output, corresponding to the "Current 1" and "Current 2" menus, which allow the user to set the corresponding channels and the upper and lower limits of the two currents.

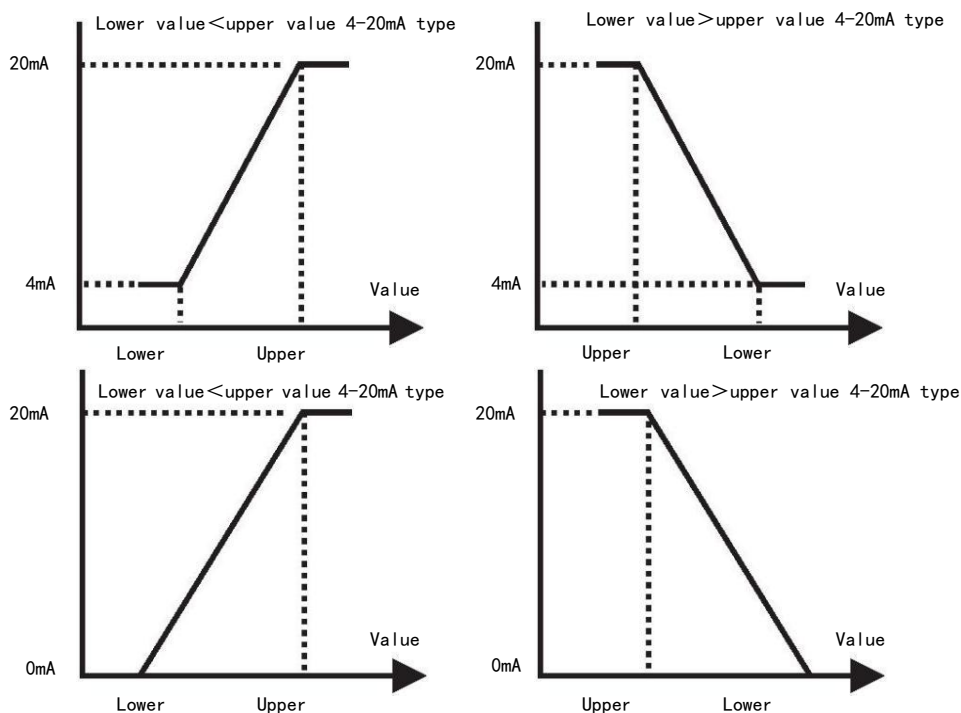

7.3.1 Output type

The output current type can be selected as “4-20mA” or “0-20mA”.

7.3.2 Channel selection

The measurement value corresponding to the current can be specified as the “main measurement channel” or “temperature channel”.

7.3.3 Upper limit value

Specify the measured value corresponding to the maximum output current.

7.3.4 Lower limit value

Specify the measured value corresponding to the minimum output current.

7.4 Communication settings	The instrument provides one digital communication interface, this menu can set the communication interface parameters.
7.4.1 Slave Address	Sets the slave address used by the instrument in the communication network.
7.4.2 Baud rate	Select the baud rate to be used for the communication interface.
7.4.3 Check bit	Select the check mode, the default is “No parity”.
7.4.4 Stop bit	Select the number of stop bits, the default is “one bit”.
7.5 System settings	Select the system display text as “Chinese” or “English”.
7.5.1 System language	Set the system time "year, month, day" and "hour, minute, second".
7.5.2 Time setting	
7.5.3 Display rate	Adjust the rate of the change of the measured display value. The display rate from fast to slow is “buffered 2”, “buffered 4”, “buffered 8”, “buffered 16”, and “buffered 32”.
7.5.4 Backlight selection	Set the working mode of the LCD backlight. If it is set to “energy saving” mode, the backlight will automatically turn off if there is no key operation within the set time.
7.5.5 Contrast setting	Set the contrast of the LCD display, the left key decreases the contrast. the right key increases the contrast.
7.5.6 Version information	View program version information.
7.5.7 Password setting	Used to set the verification password to be entered when entering the menu in the measurement mode. The password is set to “000000”when leaving the factory, and you can enter the menu directly without password in the measurement mode. If the user sets other password, they will be prompted to enter the password when entering, and the password will be verified before entering the menu.
7.6 History record	
7.6.1 Memory information	View history storage information of the meter.
7.6.2 Recording interval	Set the interval time for the meter to record measurement data. The setting range is 0~999min. When the recording interval is set to 0, it means that the recording function is closed.

7.6.3 Data query

After entering the menu, you can enter the query date, and press the key  to display the latest historical data to the query point.

7.7 Test maintenance

7.7.1 Current calibration

To calibrate the current output value, take calibrating current I 20mA as an example, first connect the ammeter to the current 1 output terminal, then enter the menu “Test Maintenance” -> “Current Calibration” -> “Current 1 “ -> “Calibrate 20mA”. Press the key to increase or decrease the value displayed on the screen until the ammeter reads 20mA, then press the key  to save the calibration result.



Note: When performing current calibration operation, for each current output, two points (4mA and 20mA) need to be calibrated to achieve the calibration effect.

7.7.2 Relay testing

Two sets of relays can be tested for on or off. After entering, select “close” or “open” and the corresponding relay will make an open or close action.

7.7.3 Current testing

Two current outputs can be tested. First, connect the ammeter to the current output terminal to be tested, enter the menu and change the output current value by pressing the key, and verify whether the meter current output is correct by the ammeter reading.

7.7.4 Measurement method

The measurement value can be set to “Electrode measurement” or “Analog measurement” .  
 Electrode measurement: The measured value displayed on the screen is the value measured by the electrode.  
 Analog measurement: The measured value is displayed as the input value set by the user.

7.7.5 Ambient temperature

Ambient temperature value: Display the current ambient temperature value.  
 Ambient temperature calibration: Calibrate the ambient temperature measurement value of the meter.  
 Buzzer alarm: Set whether the buzzer outputs an alarm sound when the ambient temperature is alarmed.

7.7.6 Meter reset

The instrument calibration parameters and all setting parameters can be restored to the factory default state.

7.8 Setting List

All calibration and setting parameters of the instrument can be viewed.

## Appendix

### A Modbus register information

#### 1. Modbus RTU Overview:

The instrument acts as a slave on the network and supports the Modbus RTU communication protocol.

The data communication is initiated by the host and the first byte of the transmitted message is the target slave address. When the first byte is received by all slaves on the network, each slave will decode it to determine whether the message is sent to itself.

The transmission of the RTU message frame starts with a pause interval of at least 3.5 characters. After the last character is transmitted, a pause of at least 3.5 characters marks the end of the message frame. A new message can start after this pause. In the transmission process, the entire message frame must be transmitted in a continuous stream. If there is a pause of more than 1.5 characters before the completion of the message frame transmission, the receiving device will refresh the incomplete message and assume that the next byte is the start of the new message. Similarly, if a new message starts after the previous message frame in less than 3.5 character, the receiving device will assume that it is a continuation of the previous frame, and this will cause an error because the last CRC value cannot be correct.

The meter uses the function code 0x04 to complete the output of the measurement result and the output of the two current values.

#### 2. Function code details (function code

This function enables the host (upper computer) to obtain the real-time measured value from the slave (instrument). The value is specified as a single-precision floating-point type (that is, occupying 2 consecutive register addresses), and the corresponding parameter are marked by different register address.

The host can send the command frames to read single or all data results. The data frame format is as follows (all data are in Hex format):

##### Host send:

1	2	3	4	5	6	7	8
Slave address	Function code	Register start Address high 8 bit	Register start address low 8 bit	Register number high 8 bit	Register number low 8 bit	CRC low 8 bit	CRC high 8 bit
Addr	04	xx	xx	xx	xx	CRC	CRC

**Slave response:**

1	2	3	4	5	5+n	5+n+1	5+n+2	5+n+3
Device Address	Function code	Length	Data 1 high 8 bit	Data 1 low 8 bit	Data n high 8 bit	Data n low 8 bit	CRC low 8 bit	CRC high 8 bit
Addr	04	Len	xx	xx	xx	xx	CRC	CRC



Note : 1. Addr is the slave address, with an optional range of 0 x 01 to 0 x FE.  
2. Len is the number of bytes of returned data.

**Examples:**

Send frame: [01 04 00 02 00 02 D0 0B], the meaning is as follows:

[01]: Instrument address

[04]: Function code

[00 02]: Starting register address 0 x 02

[00 02]: Read 2 registers from the start address (read a single-precision floating-point data result)

[D0 0B]: CRC check data

Return frame: [01 04 04 CC CD 41 48 65 4D], the meaning is as follows:

[01]: Instrument address

[04]: Function code

[04]: The number of bytes returned (here 4)

[CC CD 41 48]: 0 x 4148CCCD (12.55 floating-point values, specific numerical meaning to find the corresponding address) (Note: 16-bit integer registers coalition of a single-precision floating-point, pay attention to the order of the data)

[65 4D]: CRC check data

**3. Corresponding parameter table of communication**

According to the measurement object, the meter is connected to different electrodes. Please refer to the "Digital Universal Controller Electrode Setting Instructions" for the corresponding parameter table of the communication address.



---

**Suzhou Delfino Environmental Technology CO., Ltd**  
**[www.daruifuno.com](http://www.daruifuno.com)**  
**[info@daruifuno.com](mailto:info@daruifuno.com)**